

- FREE SPACE IN THE REAR BODY TO TRANSPORT MATERIALS
- SINGLE CAB VEHICLE
- FROM 2.8 TON

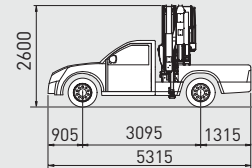

12 m	4.5 m	150 kg	180°	A	min. 2.8 Ton

- KING CAB & DOUBLE CAB VEHICLE
- ARTICULATED TERMINAL FLY BOOM - JIB
- FROM 3.2 TON

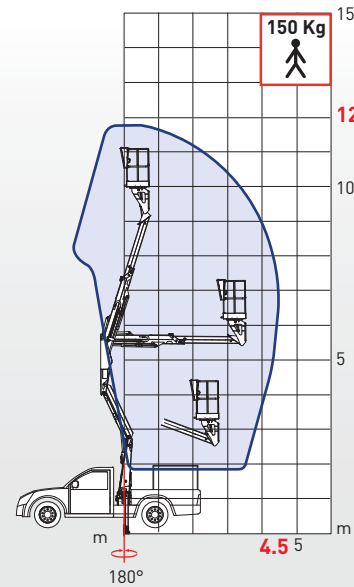
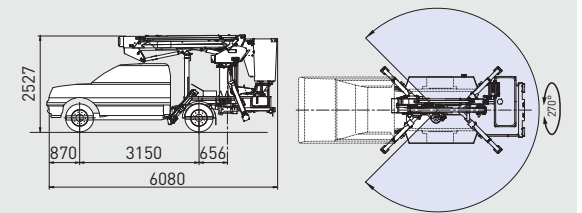
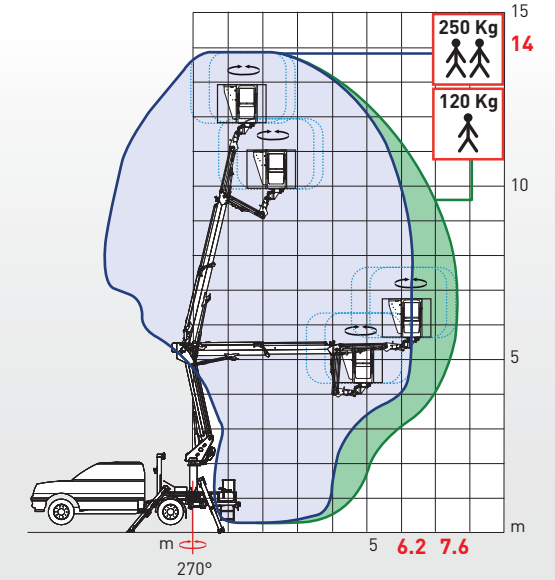

14 m	6.2 (7.6) m	250 (120) kg	270°	90° + 90°	A + A min. 3.2 Ton

- FREE SPACE IN THE REAR BODY TO TRANSPORT MATERIALS
- SINGLE CAB VEHICLE
- FROM 2.8 TON

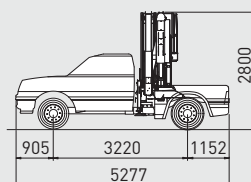
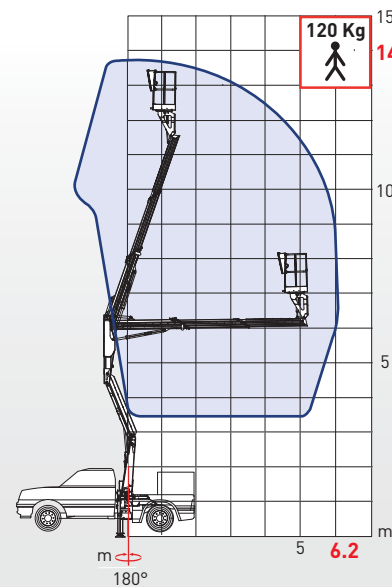

14 m	6.2 m	120 kg	180°	HE	min. 2.8 Ton

- SINGLE CAB VEHICLE
- DOUBLE PANTOGRAPH
- ARTICULATED TERMINAL FLY BOOM - JIB
- FROM 3.2 TON

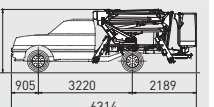
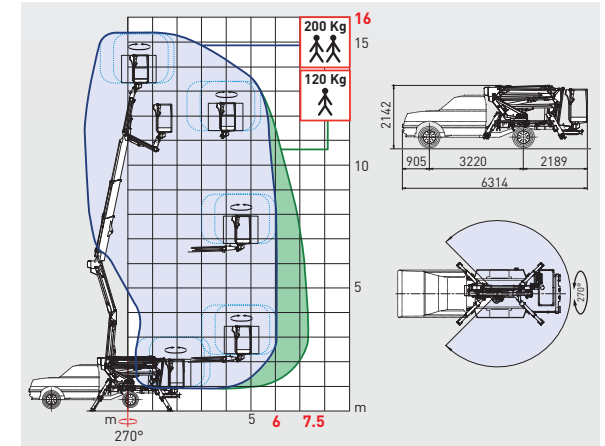
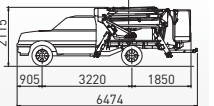
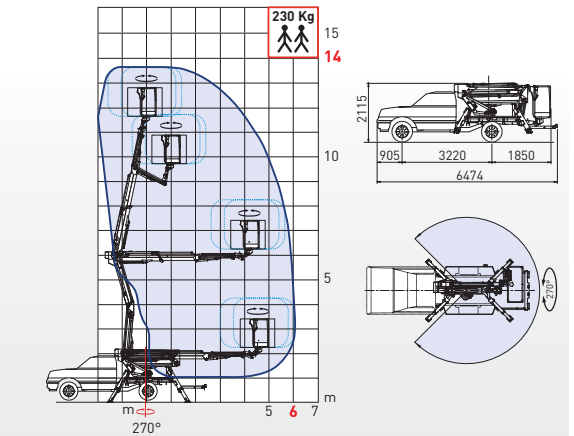

14 m	6 m	230 kg	270°	90° + 90°	A + A min. 3.2 Ton
16 m	6 (7.5) m	200 (120) kg	270°	90° + 90°	A + A min. 3.2 Ton